

INSTALLATION AND OPERATING INSTRUCTIONS FOR PBS SWITCH (PHOTOCELL) ITEM NO. KNL102

Specifications

- Technology: Infrared (Photocell)
- Receiver range: $\leq 20\text{m}$. Range can be reduced to 30% in bad weather conditions, such as rain, dust etc.
- Frequency: 1.92 KHz
- Power supply: 12 to 24V DC/AC
- Wave length: 940nm
- Input: RX 15mA-TX 30mA, Angle: $<\pm 10^\circ$
- Working temperature: -20°C - $+70^\circ\text{C}$
- Relay output: 1A max 30V

Wire Connection With KNL Series Swing Gate Opener

Remove the up cover of the PBS Switch. Find 2 terminals in the emitter and 5 terminals in the receiver. The user is suggested to prepare power wire and signal wire long enough according to on-site installation work.

(1) Power wire connection

Use a 2-core cable to connect the “- ~” terminal of the photocell’s emitter to the “BAT-” terminal of the control board, the “+ ~” terminal to the “COM” terminal. Also the “- ~” and “+ ~” terminals of the photocell’s receiver should be connected to the “BAT-” and “COM” terminals in parallel.

(2) Signal cable connection

Use wires to connect 2 terminals marked “COM” and “NC” in the receiver with the PHOTOCELL terminals in the Control Board.

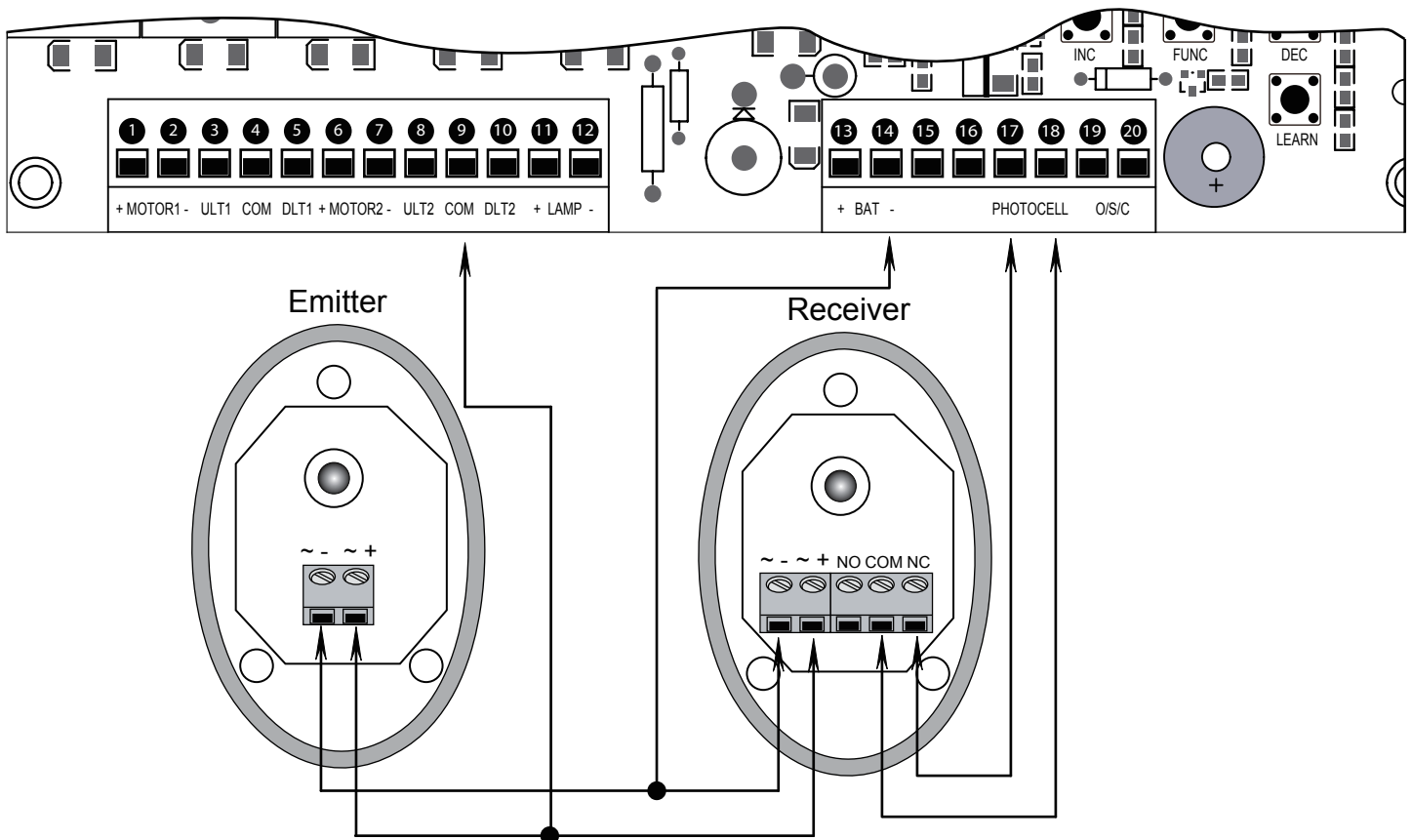

NOTE: The user must choose either way of wire connection in strict accordance with his on-site requirement. Otherwise the PBS Switch will fail and the gate opener wouldn't work.

Wire Connection With KND Series (KND500) Sliding Gate Opener

Remove the up cover of the PBS Switch. Find 2 terminals in the emitter and 5 terminals in the receiver. The user is suggested to prepare power wire and signal wire long enough according to on-site installation work.

(1) Power wire connection

Use a 2-core cable to connect the “- ~” terminal of the photocell’s emitter to the “16”th terminal of the control board, the “+ ~” terminal to the “17”th terminal. Also the “- ~” and “+ ~” terminals of the photocell’s receiver should be connected to the “16”th and “17”th terminals in parallel.

(2) Signal cable connection

Use wires to connect 2 terminals marked “COM” and “NC” in the receiver with the PHOTOCELL terminals(the “8”th and “9”th terminals) in the Control Board.

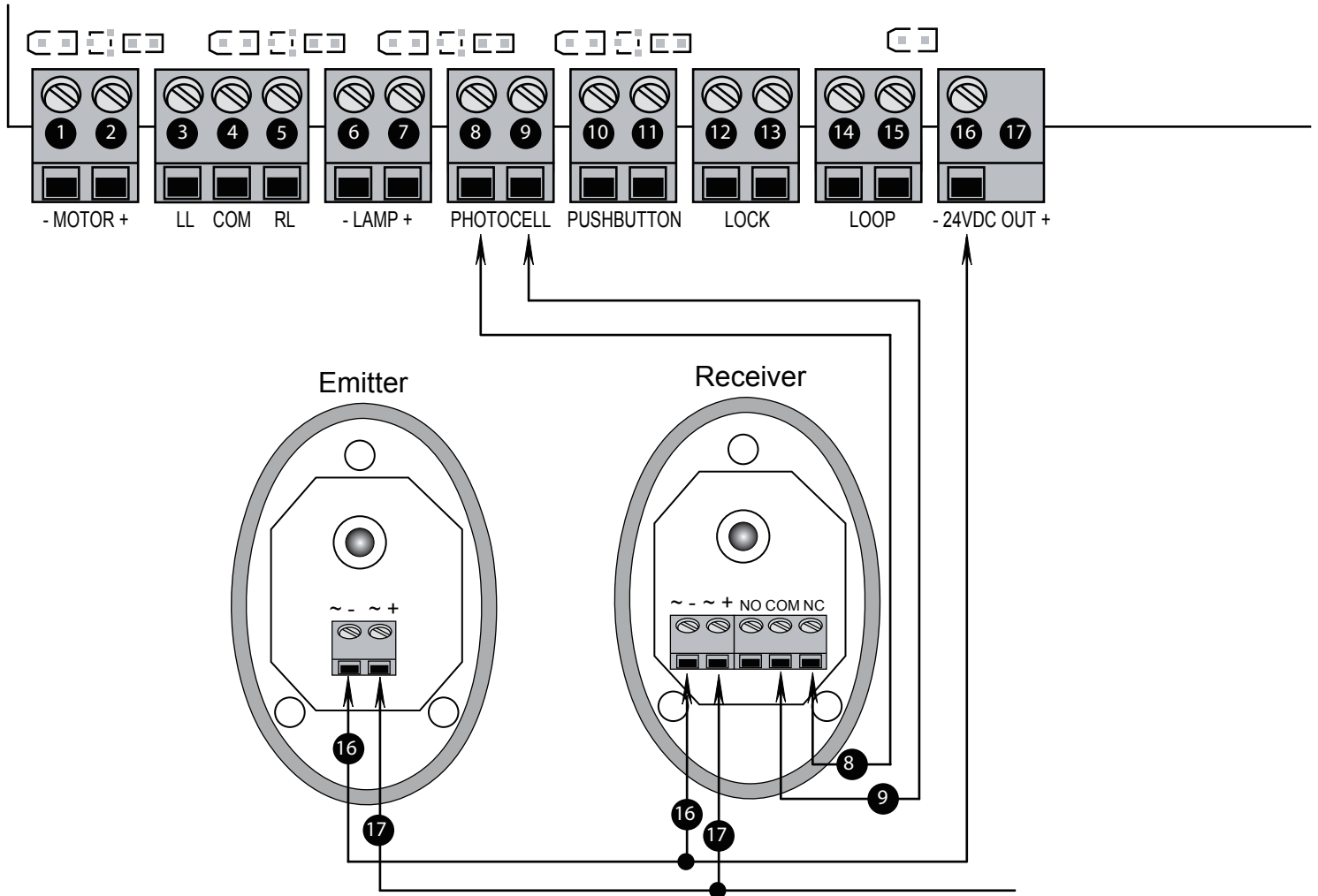

Wire Connection With KNS1500/KNS3000 Sliding Gate Opener

Remove the up cover of the PBS Switch. Find 2 terminals in the emitter and 5 terminals in the receiver. The user is suggested to prepare power wire and signal wire long enough according to on-site installation work.

(1) Power wire connection

Use a 2-core cable to connect the “+ ~” terminal of the photocell’s emitter to the “12”th terminal of the control board, the “- ~” terminal to the “13”th terminal. Also the “+ ~” and “- ~” terminals of the photocell’s receiver should be connected to the “12”th and “13”th terminals in parallel.

(2) Signal cable connection

Use wires to connect 2 terminals marked “COM” and “NO” in the receiver with the “PHO” and “COM” terminals(“14”th and “15”th terminals) in the Control Board.

Control Board Of KNS1500/KNS3000

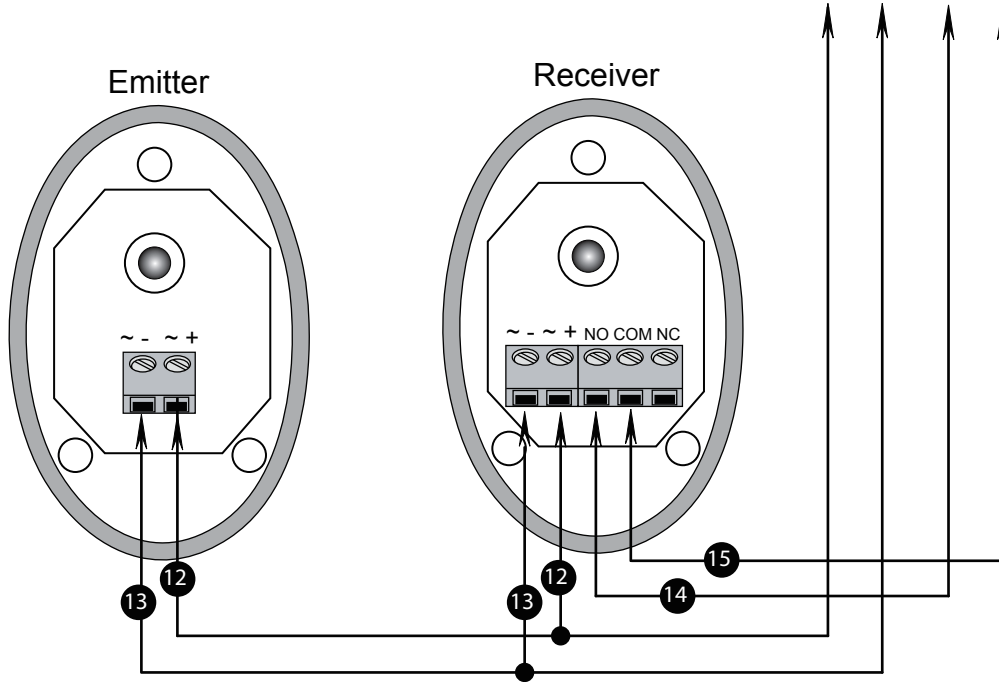
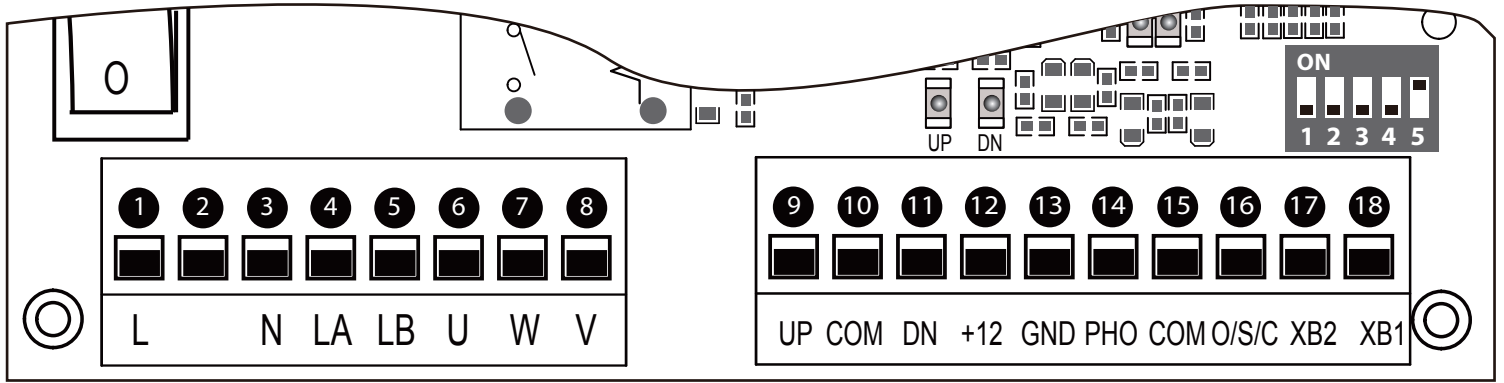

Install the PBS Switch

Note: Install the PBS Switch over the height of 20cm. Install the receiver not less than 3m away from the emitter. Vertically install the PBS Switch and keep both emitter and receiver at the same level.

The wires output direction of the PBS Switch must be down so as to avoid water ingress. . The user is recommended to add a rubber ring between the PBS Switch and the Mounting Board (not provided).

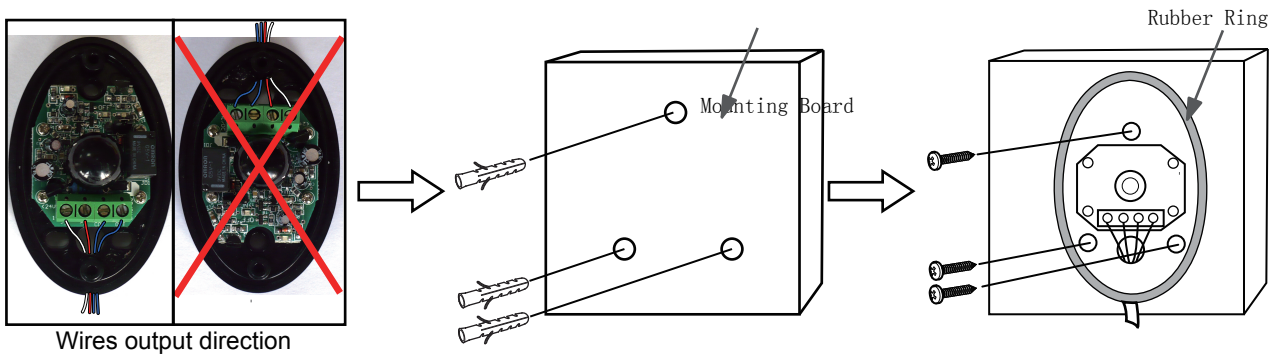

Note: With strong power, the PBS Switch may fail if the receiver is too close to the emitter. Take the receiver at least 1m away from the emitter and try again. Remove the condenser lens in both emitter and receiver if the distance is too close and the PBS Switch is not so sensitive. The PBS Switch should be sheltered from direct sunlight.